

THE HARBO LARGE CAPACITY SYRINGE

For Instrumental Insemination Of Honey Bee Queens

The Harbo Syringe is an innovative large capacity syringe designed to simplify the collection, handling, storage and shipment of semen. It is designed to increase efficiency in commercial production as well provide specific requirements for specialized research purposes and is compatible with most insemination instruments on the market.

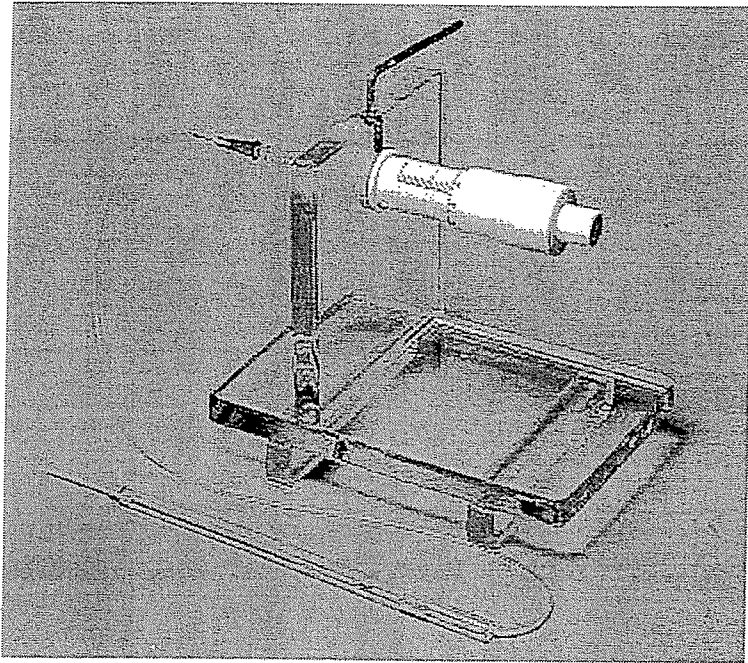

Micrometer Enables Precise Measurement Of Semen Volume

The Gilmont micrometer enables the delivery of very accurate and readable measurements of semen. The 200 microliter (μl) capacity of the syringe is calibrated in microliters with divisions of 0.2 microliter. This provides precision in the insemination of specific amounts of semen for specialized as well as production work. For example, several queens can be inseminated with the semen of one drone or one queen can be inseminated with the homogenized semen from hundreds of drones.

Detachable Capillary Tubes Enable Unlimited Semen Capacity

Designed for commercial use, semen is collected in easily detachable capillary tubes. This feature enables the efficient collection of an unlimited quantity of semen. It also simplifies the handling, storage and shipping of semen. Homogenizing large amounts of semen is also simplified.

Detachable Glass Tips Are Economical and Easy To Clean

Economical and easy to clean glass tips are used. These are also easily changeable without loss of semen. A small piece of latex tubing connects the tip to the capillary tube. This provides flexibility and helps prevent breakage of the tip.

Protective Glass Barrel Houses Semen Storage Tube

The capillary semen storage tube is housed in a protective glass barrel that is easily assembled and disassembled. The glass barrel fits into the syringe holder of most instruments on the market.

Flexibility Of Connection Points Provides Convenience

The glass tips and capillary semen storage tubes are attached with a piece of latex connector tubing. Tygon tubing connects the needle of the micrometer to the syringe assembly. These connections allow for easy and quick change of tips and semen storage tubes. These various connections also enable the versatility of adjusting the quantity of saline in the syringe if necessary during semen collection.

Separate Syringe Stand

The micrometer is housed in its own separate stand. This helps reduce the chance of unwanted movement of the syringe tip once it is properly positioned. For production work, the separate stand allow the easy transfer of semen loads between operators.

HONEY BEE INSEM. SERVICE, 7417 HAYDEN RUN RD, HILLIARD, OH 43026 USA
Contact: Susan Cobey PH (614) 777-9687, E-Mail cobey.1@osu.edu

THE HARBO LARGE CAPACITY SYRINGE ASSEMBLY AND CARE INSTRUCTIONS

**For information contact: Susan Cobey
Honey Bee Insemination Service
7417 Hayden Run Rd. Hillard, OH 43026 USA
Tel (614) 777-9687 Fax (614) 292-5237
cobey.1@osu.edu**

STERILIZATION

Sterilize syringe parts before usage. Glass parts may be heat sterilized (a pressure cooker works well, provided it has not been previously used for cooking). The tygon tubing and rubber latex connectors should be rinsed with a 5% hypochlorite solution followed by a thorough rinsing with distilled water (use a squeeze bottle or pipette).

ASSEMBLY

1. Sterilize all syringe parts and accessories. Wash hands (thoroughly) and work area with alcohol, before assembly. During assembly be sure not to touch parts coming in direct contact with the diluent (or saline solution) or semen.
2. Fill the syringe barrel (needle attached) with solution using a pipette. Be sure there are no air bubbles present.
3. Place the syringe barrel over the over the plunger of the micrometer, followed by the O ring and screw cap.
4. Expel some of the solution to remove any air bubbles (a light tap will loosen air bubbles from the neck of the needle). Take up additional solution.
5. Fit the tygon tubing over the needle and expel solution to fill the tube while making sure no air bubbles are present in the line.
6. Attach the rubber latex connector to the tygon tubing and expel solution to fill the connector.
7. Fill the capillary tube with solution by capillary action before attachment.
8. Attach the filled capillary tube to the other end of the latex connector making sure no air bubbles are present.
9. Pull the capillary tube and tygon tubing through the opening of the plexiglass stand and place the screw cap of the micrometer into the plexiglass stand so that it fits tightly into the stand, use the set screw to tighten this.
10. Place the glass barrel in the insemination instrument syringe stand with the smaller end facing down.
11. Placed the attached capillary tube through the glass barrel and push the capillary tube a short distance past the opening of the glass barrel.
12. Fit the glass tip into a second latex connector.
13. Carefully attach the latex connector with the tip onto the capillary tube.
14. Twist the latex connector with the attached glass tip to fit snugly into the glass barrel opening.
15. Expel enough solution to allow for semen uptake and to rinse the tip with solution.
16. Be sure to leave an air space between the solution and the semen before collection of semen. During collection, between drones, always keep a small amount of solution in the tip to prevent semen from drying out.
17. After inseminations clean all parts with a 5% hypochlorite solution and rinse thoroughly with distilled water.
18. To remove semen residue and mucus from glass tips after usage soak tips in a 5% hypochlorite solution overnight. This will loosen residue so that it can more easily be rinsed clean.
19. To remove difficult residue from glass tips, use a cleaning wire, from the large end only to avoid breakage of the tip.
20. Store equipment in a clean place.

SHORT TERM SEMEN STORAGE

To store semen a petrolatum seal is placed in each end of the semen filled capillary tube. The semen and petrolatum should be in direct contact with no air space.

TO SEAL SEMEN STORAGE TUBE

1. After semen has been collected, draw the semen up into the capillary tube and remove the glass tip and latex connector from the capillary tube.
2. Remove the capillary tube from the glass barrel, do not detach from the micrometer.
3. Use the micrometer to push the semen flush with the end of the capillary tube.
4. Detach the semen filled capillary tube from the syringe.
5. Petrolatum is then forced into the capillary tube from the end flush with semen. This is accomplished by holding the capillary tube vertical and forcing petrolatum (which has been placed on a flat surfaced spatula) into the tube which will push the semen column up making an airtight seal.
6. When the capillary tube contains about 7 mm. of petrolatum, slide the capillary tube sideways across the flat spatula to retain the seal.
7. Reconnect the petrolatum sealed end of the capillary tube to the micrometer and push the column of semen flush with the other end of the tube. If the tube is not completely filled it may be cut leaving enough space for a petrolatum seal at both ends.
8. Repeat the above procedure to seal both ends of the capillary tube.

STORAGE

For best results honey bee semen should be held at 21 C. Avoid sunlight and temperature extremes. **DO NOT REFRIGERATE SEMEN.**

TO REMOVE PETROLATUM SEAL

1. Assemble the syringe without the glass tip leaving both petrolatum seals in the semen filled capillary tube. No air space is needed between the petrolatum seal and solution when assembling the syringe. The petrolatum seal will serve to separate semen and solution, use it as you would an air space.
2. After assembly of the syringe and before the tip is in place, use the micrometer to push out the petrolatum seal on the tip end of the capillary tube. The seal at the other end of the tube is kept in place during insemination.
3. Take up several microliters of solution leaving an air space between the semen and solution.
4. Attach the glass tip and use the solution to rinse the tip.
5. Perform the inseminations.
6. Do not use the last micrometer of semen. After the inseminations are performed, take up enough saline to remove the petrolatum seal from the tip and back into the capillary tube for disposal. Be sure not to get petrolatum in the narrow part of the glass tip, this will be very difficult to remove.
7. Clean the syringe and glass tip and store in a clean place.

REPLACEMENT PARTS

***IMPORTANT**

Note that the Gilmont glass barrel is custom made for HBIS to have a larger bore in the luer tip of the syringe. This has an 1.5 mm I.D. as compared to the standard 0.25mm I.D. This dimensional specification is important to avoid air bubbles lodging in the needle head which will cause a "spongy" response and inaccurate measurement of volume.